

LIQUI-MOVER® CONDENSATE HANDLING SYSTEM SUBMITTAL

PROJECT OR CUSTOMER:	REPRESENTATIVE:	
	ENGINEER:	
	CONTRACTOR:	
REFERENCE:	ORDER NO:	DATE:
	APPROVED BY:	DATE:
	SUBMITTED BY:	DATE:

MODEL: LMHT-16XX-LRSM-FSA-1
 (XX) Designates Check Valve Size – See Chart B

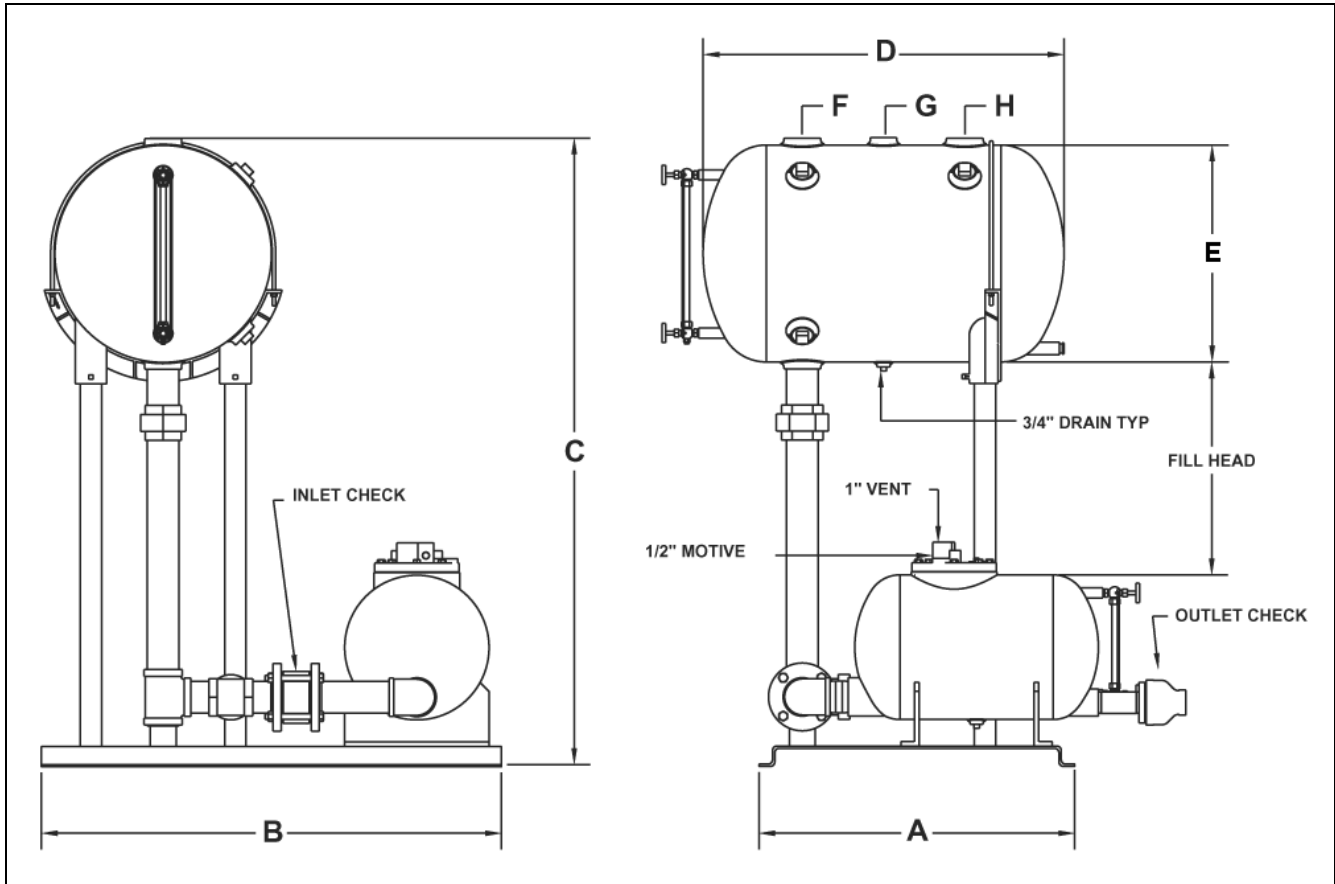

Approximate Dimensions (in inches)								
A	B	C	D	E	F	G	H	Fill Head
35	51	See Chart A	40	24	3	2	3	See Chart A

Note: Dimensions listed are for reference only. Firm dimensions are available on request.

Chart A	
Fill Head	Overall Height Dimension C
6"	51-1/2"
12"	57-1/2"
18"	63-1/2"
24"	69-1/2"
36"	81-1/2"

Chart B		
LMHT-16XX	Inlet Check Size	Outlet Check Size
1610	1"	1"
1615	1-1/2"	1-1/2"
1620	2"	2"
1632	3"	2"

Kadant Johnson
 805 Wood Street, Three Rivers, MI 49093 USA
 269-278-1715 fax: 269-279-5980
 www.liquimover.com



LIQUI-MOVER® CONDENSATE HANDLING SYSTEM SUBMITTAL

Material Specifications	
Part Description	Material
Receiver Tank	ASME Code Stamped 150 PSIG Shell & Heads – Carbon Steel SA-414 G
Pumping Tank	ASME Code Stamped 150 PSIG Shell & Heads – Carbon Steel SA-414 G Flange Ring – Carbon Steel SA-106 C
Float Mechanism	Mounting Flange – Cast Iron SA-278 Support Frame - Ductile Iron SA-395 w/ Nitride Surface Float, Valves, Springs and Linkage – Stainless Steel
Piping	Carbon Steel A53 – Schedule 40
Fittings	Malleable Iron 150# Threaded
Isolation Valves	Bronze B62
Skid	Carbon Steel AISI 1015
Check Valves	As Specified
Gauge Glass	Bronze Valves with Redline Glass and Brass Guard Rods

ADDITIONAL NOTES/COMMENTS: