

LIQUI-MOVER® CONDENSATE HANDLING SYSTEM SUBMITTAL

PROJECT OR CUSTOMER:	REPRESENTATIVE:	
	ENGINEER:	
	CONTRACTOR:	
REFERENCE:	ORDER NO:	DATE:
	APPROVED BY:	DATE:
	SUBMITTED BY:	DATE:

MODEL: LMHT-5XX-LRSM-FSA-2
 (XX) Designates Check Valve Size – See Chart B

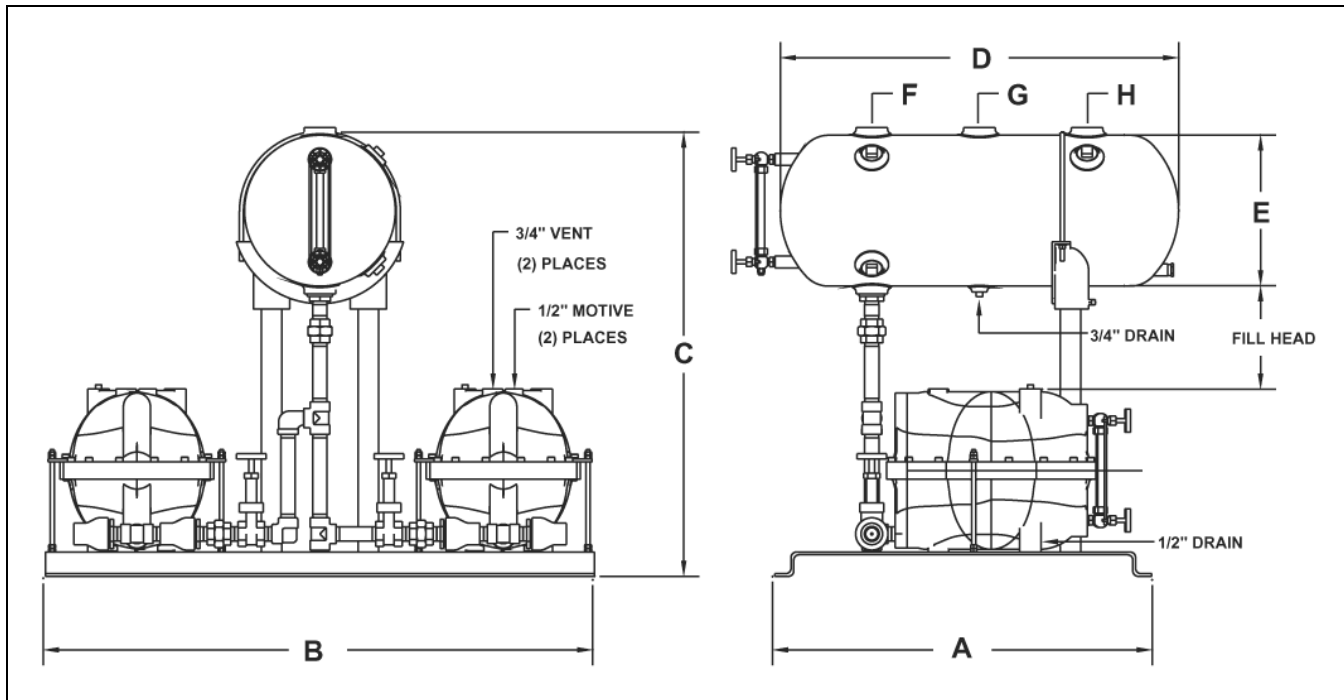

Approximate Dimensions (in inches)								
A	B	C	D	E	F	G	H	Fill Head
35	51	See Chart A	37	14	2	2	2	See Chart A

Note: Dimensions listed are for reference only. Firm dimensions are available on request.

Chart A	
Fill Head	Overall Height Dimension C
6"	37- ⁷ / ₈ "
12"	43- ⁷ / ₈ "
18"	49- ⁷ / ₈ "
24"	55- ⁷ / ₈ "
36"	67- ⁷ / ₈ "

Chart B		
LMHT-5XX	Inlet Check Size	Outlet Check Size
510	1"	1"

LIQUI-MOVER® CONDENSATE HANDLING SYSTEM SUBMITTAL

Material Specifications	
Part Description	Material
Receiver Tank	ASME Code Stamped 150 PSIG Shell & Heads – Carbon Steel SA-414 G
Pumping Tank	ASME Rated 200 PSIG Tank Top & Bottom – Ductile Iron SA-395 CL 60 SHCS – Carbon Steel SA-574
Float Mechanism	Support Frame - Ductile Iron SA-395 w/ Nitride Surface Float, Valves, Springs and Linkage – Stainless Steel
Piping	Carbon Steel A53 – Schedule 40
Fittings	Malleable Iron 150# Threaded
Isolation Valves	Bronze B62
Skid	Carbon Steel AISI 1015
Check Valves	As Specified
Gauge Glass	Bronze Valves with Redline Glass and Brass Guard Rods

ADDITIONAL NOTES/COMMENTS: