

*non-electric
condensate
pumping trap*

LMHT-1600 LOW PROFILE PRESSURE POWERED PUMP

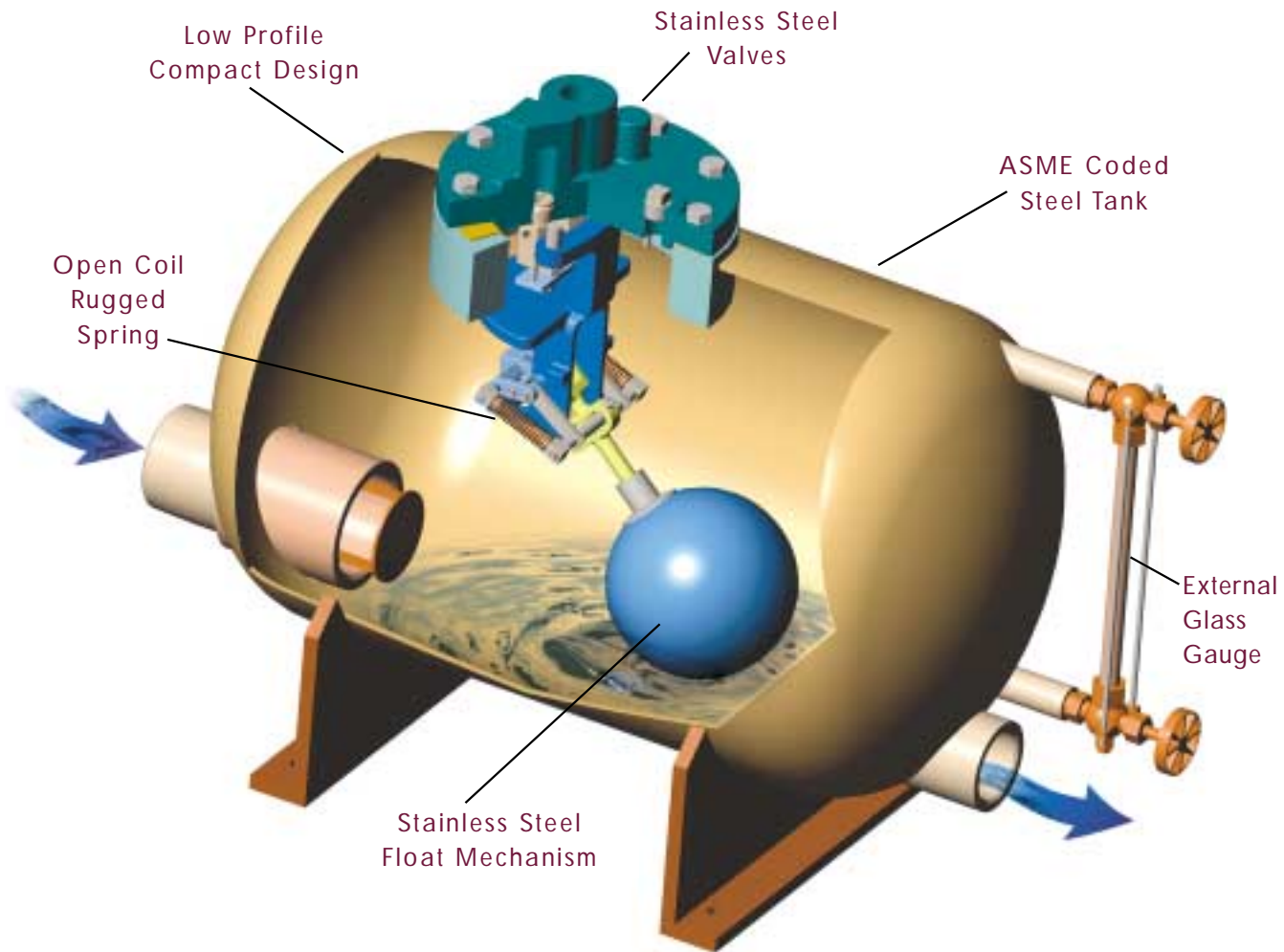

Features

- Compact design, low profile
- Non-electric
- No rotating parts
- Stainless steel float mechanism
- Exhaustive testing in R&D
- Designed for high temperature condensate
- Air or steam motive

Benefits

- Low fill head requirement
- Reduced operating cost
- Greater reliability and lower maintenance
- Wear and corrosion resistant
- Trouble-free, proven technology
- Reduced flash steam
- Operating flexibility

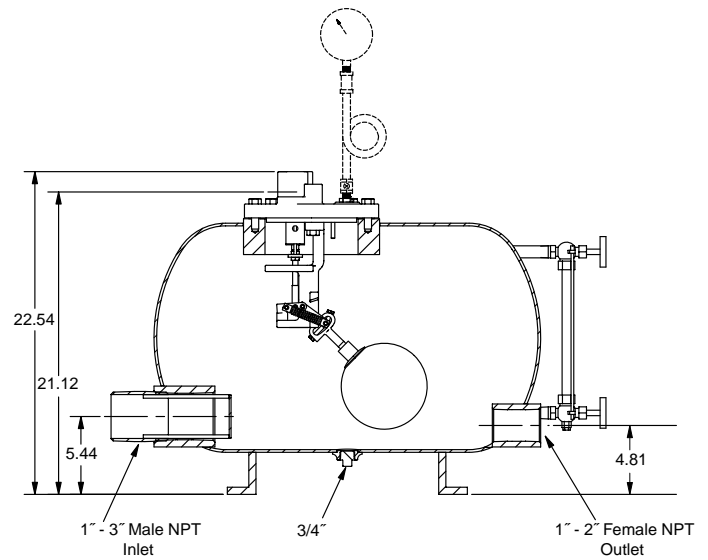
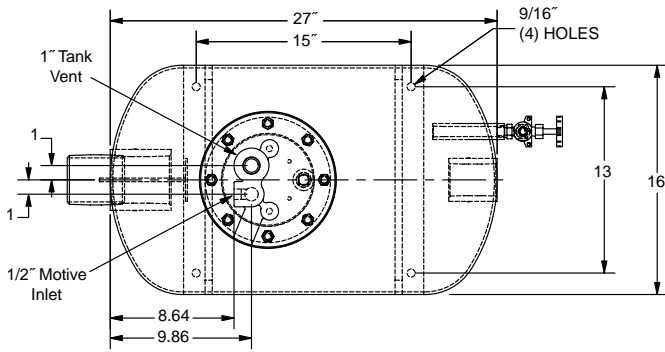

LMHT-1600 Capacities

FILL HEAD (ft)	BACK PRESSURE (psig)	LMHT 1610 1" x 1"		LMHT 1615 1-1/2" x 1-1/2"		LMHT 1620 2" x 2"		LMHT 1632 3" x 2"	
		(lbs/hr)	GPM	(lbs/hr)	GPM	(lbs/hr)	GPM	(lbs/hr)	GPM
0.5	10	2730	5.68	6580	13.7	10130	21.1	12220	25.5
	20	2720	5.67	6500	13.5	9910	20.6	11940	24.9
	30	2690	5.60	6350	13.2	9560	19.9	11430	23.8
	40	2630	5.48	6050	12.6	8920	18.6	10570	22.0
1.0	10	3030	6.31	7150	14.9	10770	22.4	13210	27.5
	20	3010	6.27	7060	14.7	10520	21.9	12780	26.6
	30	2920	6.08	6880	14.3	10120	21.1	12200	25.4
	40	2850	5.94	6530	13.6	9410	19.6	11250	23.4
1.5	10	3270	6.81	7600	15.8	11250	23.4	13710	28.6
	20	3190	6.65	7500	15.6	10960	22.8	13370	27.9
	30	3150	6.56	7280	15.2	10530	21.9	12750	26.6
	40	3070	6.40	6890	14.4	9770	20.4	11630	24.2
2.0	10	2990	6.23	7600	15.8	11250	23.4	12830	26.7
	20	2980	6.21	7490	15.6	10970	22.9	12480	26.0
	30	2890	6.02	7280	15.2	10530	21.9	11940	24.9
	40	2820	5.88	6890	14.4	9770	20.4	10930	22.8
3.0	10	3490	7.27	8180	17.0	11830	24.6	14040	29.3
	20	3400	7.08	8040	16.8	11570	24.1	13710	28.6
	30	3360	7.00	7800	16.3	11090	23.1	12910	26.9
	40	3270	6.81	6460	13.5	10270	21.4	11850	24.7
4.0	10	3780	7.88	8610	17.9	12240	25.5	14830	30.9
	20	3760	7.83	8460	17.6	11960	24.9	14300	29.8
	30	3700	7.71	8210	17.1	11450	23.9	13690	28.5
	40	3590	7.48	7720	16.1	10580	22.0	12260	25.5
5.0	10	4070	8.48	8960	18.7	12630	26.3	14900	31.0
	20	4030	8.40	8810	18.4	12250	25.5	14590	30.4
	30	3950	8.23	8530	17.8	11720	24.4	13460	28.0
	40	3820	7.96	8000	16.7	10820	22.5	12120	25.3

Motive Pressure = Back Pressure + 20 psig.

Capacity is based on steam motive with swing style inlet check valve up to 24" fill head.

For fill heads greater than 24", a spring-loaded, non-slam inlet check valve is used.

Specifications

Pressure: Up to 150 psig

Temperature: Up to 450° F

Standard Operating ΔP: 90 psid

Maximum Operating ΔP: 150 psid

Options

- Pressure gauge with isolation loop
- Cycle counter
- Glass gauge assembly
- Insulation jacket
- Skid-mounted system